



Project: \_\_\_\_\_  
Customer: \_\_\_\_\_  
Engineer: \_\_\_\_\_  
Pump Manufacturer: \_\_\_\_\_

## Technical Data Submittal Document

### Model GPR Full Service Reduced Voltage Autotransformer Electric Fire Pump Controller



#### Contents:

- Data Sheets
- Dimensional Data
- Wiring Schematics
- Field Connections

Note: The drawings included in this package are for controllers covered under our standard offering.  
Actual AS BUILT drawings may differ from what is shown in this package.

From normal incoming power through Disconnecting Means (IS/CB)\*

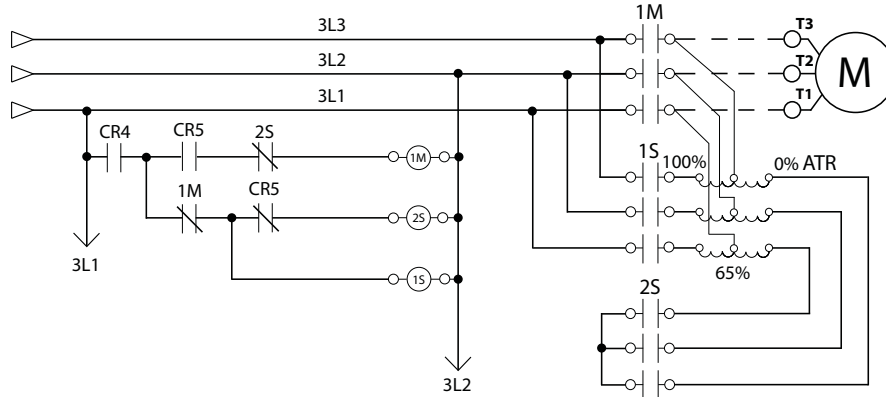

**Starting Method:** Reduced Voltage Autotransformer  
**Typical Voltage Applied at Start:** 65%  
**Inrush Current:** 42% of normal load current  
**Starting Torque:** 42%  
**Motor Type:** Across the line (direct on line)  
**No. of Contactors:** 2 at 42%, 1 at 33% of full load current (FLC)  
**Min. ampacity of motor conductors:** 3 at 125% x 100% of FLC

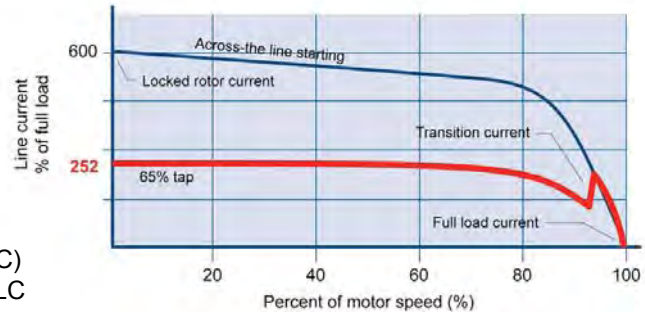

<b>Standard, Listings, Approvals and Certifications</b>	Built to NFPA 20 (latest edition)		
	Underwriters Laboratory (UL)	<ul style="list-style-type: none"> <li>• UL218 - Fire Pump Controllers</li> <li>• CSA C22.2 No. 14 Industrial Control Equipment</li> </ul>	
	FM Global	Class 1321/1323	
	New York City	Accepted for use in the City of New York by the Department of Buildings	
	<b>Optional</b>		
<input type="checkbox"/> CE Mark	Various EN, IEC & CEE directives and standards		
<b>Enclosure</b>	<b>Protection Rating</b> <input type="checkbox"/> Standard: NEMA 2 (IP31) <b>Optional</b>		
	<input type="checkbox"/> NEMA 12 <input type="checkbox"/> NEMA 3 <input type="checkbox"/> NEMA 3R <input type="checkbox"/> NEMA 4	<input type="checkbox"/> NEMA 4X-304 sst painted <input type="checkbox"/> NEMA 4X-304 sst brushed finish <input type="checkbox"/> NEMA 4X-316 sst painted <input type="checkbox"/> NEMA 4X-316 sst brushed finish	<input type="checkbox"/> IP54 <input type="checkbox"/> IP55 <input type="checkbox"/> IP65 <input type="checkbox"/> IP66
	<b>Accessories</b> <ul style="list-style-type: none"> <li>• Bottom entry gland plate</li> <li>• Lifting Lugs</li> <li>• Keylock handle</li> </ul>	<b>Paint Specifications</b> <ul style="list-style-type: none"> <li>• Red RAL3002</li> <li>• Powder coating</li> <li>• Glossy textured finish</li> </ul>	

\*Please see Disconnecting Means details on page 3.



# Technical Data Model GPR Electric Fire Pump Controller

Shortcircuit Withstand Rating	200V to 208V 60Hz	220V to 240V 60Hz	380V to 416V 50 Hz / 60Hz	440V to 480V 60Hz	575V to 600V 60Hz
	HP (kw)				
<input type="checkbox"/> Standard 100kA	5-150 (3.7 - 110)	5-200 (3.7 - 147)	5-300 (3.7 - 220)	5-450 (3.7 - 335)	n/a
<input type="checkbox"/> Optional 150kA					
<input type="checkbox"/> Standard 50kA	200 (147)	250 (184)	350 - 450 (257-335)	500 (373)	5-500 (3.7- 373)
<input type="checkbox"/> Optional 100kA	n/a	n/a	n/a	n/a	
<b>Ambient Temperature Rating</b>	<b>Standard:</b> <input type="checkbox"/> 5°C to 40°C / 41°F to 104°F		<b>Optional:</b> <input type="checkbox"/> 5°C to 50°C / 41°F to 122°F <input type="checkbox"/> 5°C to 55°C / 41°F to 131°F		
<b>Surge Suppression</b>	Surge arrestor rated to suppress surges above line voltage				
<b>Disconnecting Means</b>	<ul style="list-style-type: none"> <li>Isolating switch and circuit breaker assembly:               <ul style="list-style-type: none"> <li>Door interlocked in the ON position</li> <li>Isolating switch rated not less than 115% of motor full load current</li> <li>Circuit breaker continuous rating not less than 115% of motor full load current</li> <li>Overcurrent sensing non-thermal type, magnetic only</li> <li>Instantaneous trip setting of not more than 20 times the motor full load current</li> </ul> </li> <li>Common flange mounted operating handle</li> </ul>				
<b>Service Entrance Rating</b>	Suitable as service entrance equipment				
<b>Emergency Start Handle</b>	<ul style="list-style-type: none"> <li>Flange mounted</li> <li>Pull and latch activation</li> </ul>		<ul style="list-style-type: none"> <li>Integrated limit switch</li> <li>Across the line start (direct on line)</li> </ul>		
<b>Locked Rotor Protector</b>	<ul style="list-style-type: none"> <li>Operate shunt trip to open circuit breaker</li> <li>Factory set at 600% of motor full load current</li> </ul>		<ul style="list-style-type: none"> <li>Trip between 8 and 20 seconds</li> </ul>		
<b>Electrical Readings</b>	<ul style="list-style-type: none"> <li>Voltage phase to phase (normal power)</li> <li>Amperage of each phase when motor is running</li> </ul>				
<b>Pressure Readings</b>	<ul style="list-style-type: none"> <li>Continuous system pressure display</li> <li>Cut-in and Cut-out pressure settings</li> </ul>				
<b>Pressure and Event recorder</b>	<ul style="list-style-type: none"> <li>Pressure readings with date stamp</li> <li>Event recording with date stamp</li> <li>Under regular maintained operation, events can be stored in memory for up to 5 years.</li> <li>Data viewable on operator interface display screen</li> <li>Downloadable by USB port to external memory device</li> </ul>				
<b>Pressure Sensing</b>	<ul style="list-style-type: none"> <li>Pressure transducer and run test solenoid valve assembly for fresh water application</li> <li>Pressure sensing line connection 1/2" Female NPT</li> <li>Drain connection 3/8"</li> <li>Rated for 0-500PSI working pressure (calibrated at 0-300psi)</li> <li>Externally mounted with protective cover</li> </ul>				



# Technical Data Model GPR Electric Fire Pump Controller

<b>Audible Alarm</b>	4" alarm bell - 85 dB at 10ft. (3m)		
<b>Visual Indications &amp; Alarms</b>	<ul style="list-style-type: none"> <li>• Power available</li> <li>• Phase reversal</li> <li>• Motor run</li> <li>• Pump room alarm</li> <li>• Motor trouble</li> <li>• Phase loss</li> <li>• Phase unbalance</li> <li>• Low water level</li> </ul>	<ul style="list-style-type: none"> <li>• Locked rotor</li> <li>• Periodic test</li> <li>• Fail to start</li> <li>• Low discharge pressure</li> <li>• Low pump room temperature</li> <li>• Pump room temperature (°F or °C)</li> <li>• Pump on demand/Automatic start</li> <li>• Emergency start</li> </ul>	<ul style="list-style-type: none"> <li>• Manual start</li> <li>• Deluge valve start</li> <li>• Remote automatic start</li> <li>• Remote manual start</li> <li>• Overcurrent</li> <li>• Undercurrent</li> <li>• Undervoltage</li> <li>• Overvoltage</li> </ul>
<b>Remote Alarm Contacts</b>	SPDT-8A-250V.AC <ul style="list-style-type: none"> <li>• Power available</li> <li>• Phase reversal</li> <li>• Motor run</li> <li>• Common pump room alarm (field re-assignable)**               <ul style="list-style-type: none"> <li>• Overvoltage</li> <li>• Undervoltage</li> <li>• Phase unbalance</li> <li>• Low pump room temperature</li> <li>• High Pump room temperature</li> </ul> </li> <li>• Common motor trouble (field re-assignable)**               <ul style="list-style-type: none"> <li>• Overcurrent</li> <li>• Fail to start</li> <li>• Undercurrent</li> <li>• Ground fault</li> </ul> </li> <li>• Free (field programmable)**</li> </ul>		
<b>ViZiTouch Operator Interface</b>	<ul style="list-style-type: none"> <li>• Embedded microcomputer with software PLC logic</li> <li>• 4.2" color touch screen (HMI technology)</li> <li>• Upgradable software</li> <li>• Expandable storage</li> <li>• Multi-language</li> </ul>		
<b>Operation</b>	<b>Automatic Start</b>	<ul style="list-style-type: none"> <li>• Start on pressure drop</li> <li>• Remote start signal from automatic device</li> </ul>	
	<b>Manual Start</b>	<ul style="list-style-type: none"> <li>• Start pushbutton</li> <li>• Run test pushbutton</li> <li>• Deluge valve start</li> <li>• Remote start from manual device</li> </ul>	
	<b>Stopping</b>	<ul style="list-style-type: none"> <li>• Manual with Stop pushbutton</li> <li>• Automatic after expiration of minimum run timer ***</li> </ul>	
	<b>Timers</b>	Field Adjustable & Visual Countdown	<ul style="list-style-type: none"> <li>• Minimum run timer ***(off delay)</li> <li>• Sequential start timer (on delay)</li> <li>• Periodic test timer</li> </ul>
	<b>Actuation</b>	Visual Indication	<ul style="list-style-type: none"> <li>• Pressure</li> <li>• Non-pressure</li> </ul>
	<b>Mode</b>		<ul style="list-style-type: none"> <li>• Automatic</li> <li>• Non-automatic</li> </ul>

\*\*Tornatech reserves the right to use any of these three alarm points for special specific application requirements.

\*\*\*Can only be used if approved by the AHJ



# Technical Data Model GPR Electric Fire Pump Controller

<input type="checkbox"/> A4	Flow switch provision
<input type="checkbox"/> A8	Foam pump application w/o pressure transducer and run test solenoid valve
<input type="checkbox"/> A9	Low zone pump control function
<input type="checkbox"/> A10	Medium zone pump control function
<input type="checkbox"/> A11	High zone pump control function
<input type="checkbox"/> A13	Non-pressure actuated controller w/o pressure transducer and run test solenoid valve
<input type="checkbox"/> A16	Lockout/interlock circuit from equipment installed inside the pump room
<input type="checkbox"/> B11	Built in alarm panel (120V.AC supervisory power) providing indication for: • Audible alarm & silence pushbutton for motor run, phase reversal, loss of phase. • Pilot lights for loss of phase & supervisory power available
<input type="checkbox"/> B11B	Built in alarm panel same as B11 but 220-240VAC supervisory power
<input type="checkbox"/> B19	High motor temperature thermistor relay c/w visual indication and alarm contact (Form C-SPDT)
<input type="checkbox"/> B21	Ground fault alarm detection c/w visual indication and alarm contact (Form C-SPDT)
<input type="checkbox"/> C1	Extra motor run alarm contact (Form C-SPDT)
<input type="checkbox"/> C4	Periodic test alarm contact (Form C-SPDT)
<input type="checkbox"/> C6	Low discharge pressure alarm contact (Form C-SPDT)
<input type="checkbox"/> C7	Low pump room temperature alarm contact (Form C-SPDT)
<input type="checkbox"/> C10	Low water reservoir level alarm contact (Form C-SPDT)
<input type="checkbox"/> C11	High electric motor temperature alarm contact (Form C-SPDT)
<input type="checkbox"/> C12	High electric motor vibration c/w visual indication and alarm contact (Form C-SPDT)
<input type="checkbox"/> C14	Pump on demand/automatic start alarm contact (Form C-SPDT)
<input type="checkbox"/> C15	Pump fail to start alarm contact (Form C-SPDT)
<input type="checkbox"/> C16	Control voltage healthy alarm contact (Form C-SPDT)
<input type="checkbox"/> C17	Flow meter valve loop open c/w visual indication and alarm contact (Form C-SPDT)
<input type="checkbox"/> C18	High water reservoir level c/w visual indication and alarm contact (Form C-SPDT)
<input type="checkbox"/> C19	Emergency start alarm contact (Form C-SPDT)

<input type="checkbox"/> C20	Manual start alarm contact (Form C-SPDT)
<input type="checkbox"/> C21	Deluge valve start alarm contact (Form C-SPDT)
<input type="checkbox"/> C22	Remote automatic start alarm contact (Form C-SPDT)
<input type="checkbox"/> C23	Remote manual start alarm contact (Form C-SPDT)
<input type="checkbox"/> C24	High pump room temperature alarm contact (Form C-SPDT)
<input type="checkbox"/> Cx	Additional visual and alarm contact (specify function) (Form C-SPDT)
<input type="checkbox"/> D1	Low suction pressure transducer for fresh water rated at 0-300PSI with visual indication and alarm contact
<input type="checkbox"/> D1A	Low suction pressure transducer for sea water rated at 0-300PSI with visual indication and alarm contact
<input type="checkbox"/> D5	Pressure transducer and run test solenoid valve for fresh water rated for 0-500PSI (for calibration purposes only)
<input type="checkbox"/> D5D	Pressure transducer and run test solenoid valve for sea water rated for 0-500PSI
<input type="checkbox"/> D10	Omit mounting feet (when applicable)
<input type="checkbox"/> D13	High withstand rating for: • 208V to 480V = 150kA • 600V = 100kA
<input type="checkbox"/> D14	Anti-condensation heater & thermostat
<input type="checkbox"/> D14A	Anti-condensation heater & humidistat
<input type="checkbox"/> D14B	Anti-condensation heater & thermostat & humidistat
<input type="checkbox"/> D15	Tropicalization
<input type="checkbox"/> D18	CE Mark with factory certificate
<input type="checkbox"/> D26	Modbus RTU provision
<input type="checkbox"/> D26A	Modbus TCP/IP provision
<input type="checkbox"/> D27	Motor heater connection (external single phase power source and heater on/off contact)
<input type="checkbox"/> D27A	Motor heater connection (internal single phase power source and heater on/off contact)
<input type="checkbox"/> D28	Customized drawing set
<input type="checkbox"/> D34	Field programmable I/O board - 8 Input / 5 output
<input type="checkbox"/> D35	Field programmable I/O board - 8 Input / 10 output
<input type="checkbox"/> D36	Redundant pressure transducer for fresh water rated for 0-500PSI (calibrated at 0-300PSI)
<input type="checkbox"/> D36A	Redundant pressure transducer for sea water rated for 0-500PSI (calibrated at 0-300PSI)
<input type="checkbox"/> D37	Window kit for operator interface

Note: Options chosen from this page are not electrically represented on the wiring schematics in this submittal package.



## Technical Data Model GPR Electric Fire Pump Controller

<input type="checkbox"/> L01	Other language and English (bilingual)
<input type="checkbox"/> L02	French
<input type="checkbox"/> L03	Spanish
<input type="checkbox"/> L04	German
<input type="checkbox"/> L05	Italian
<input type="checkbox"/> L06	Polish
<input type="checkbox"/> L07	Romanian
<input type="checkbox"/> L08	Hungarian
<input type="checkbox"/> L09	Slovak
<input type="checkbox"/> L10	Croatian

<input type="checkbox"/> L11	Czech
<input type="checkbox"/> L12	Portuguese
<input type="checkbox"/> L13	Dutch
<input type="checkbox"/> L14	Russian
<input type="checkbox"/> L15	Turkish
<input type="checkbox"/> L16	Swedish
<input type="checkbox"/> L17	Bulgarian
<input type="checkbox"/> L18	Thai
<input type="checkbox"/> L19	Indonesian
<input type="checkbox"/> L20	Slovenian

Note: Options chosen from this page are not electrically represented on the wiring schematics in this submittal package.

### ViZiTouch Operator Interface

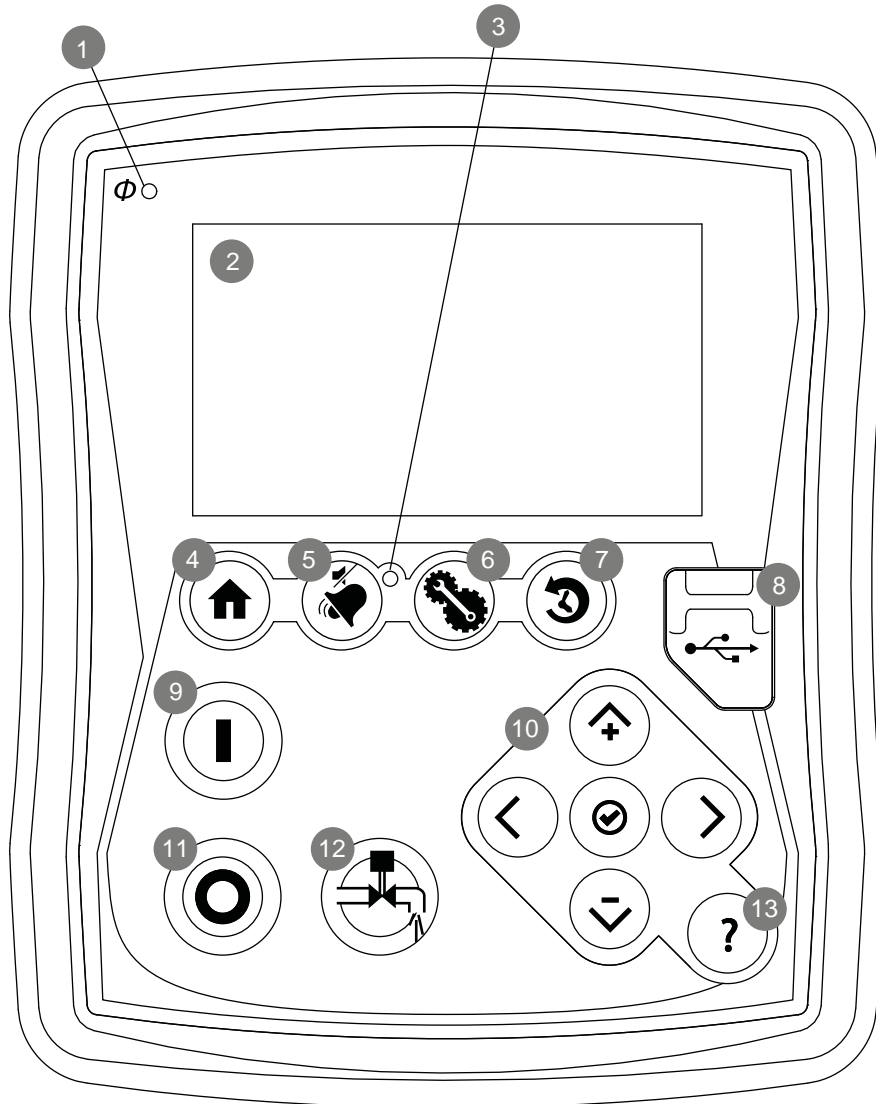

1 - Power on LED

2 - Color touch screen

3 - Alarm LED

4 - HOME page button

5 - ALARM page button

6 - CONFIGURATION page button

7 - HISTORY page button

8 - USB port

9 - START button

10 - Contextual navigation pad

11 - STOP button

12 - RUN TEST button

13 - HELP button

## Dimensions

BUILT TO THE LATEST EDITION OF THE NFPA20 STANDARD

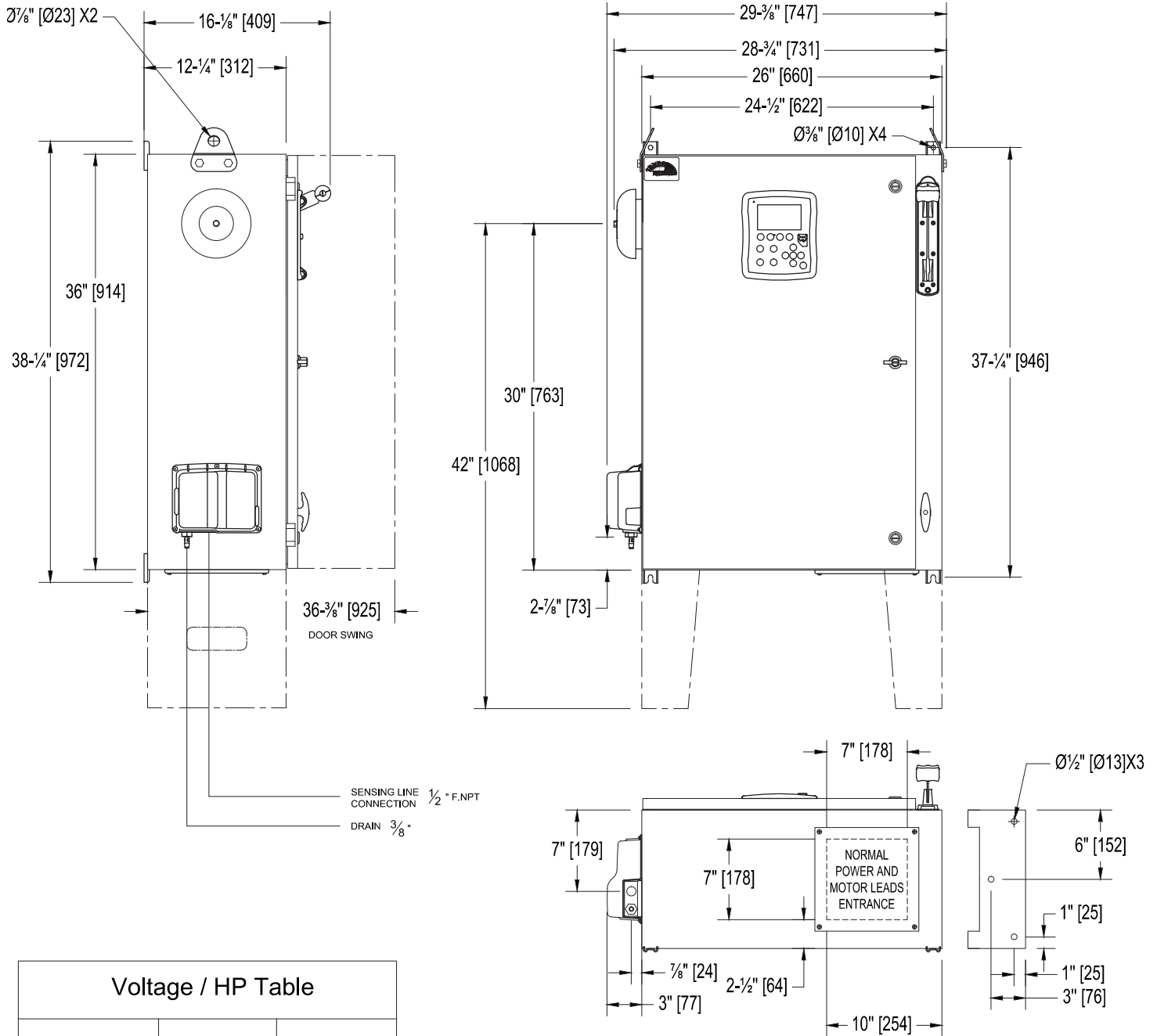

Voltage / HP Table

Voltage	Min HP	Max HP
208	5	30
220 - 240	5	30
380 - 400 - 415	5	60
440 - 480	5	60
600	5	75

### NOTES :

- ALL DIMENSIONS ARE IN INCHES (MILLIMETERS).
- PAINT : TEXTURED RED RAL 3002.
- BOTTOM CONDUIT ENTRANCE THROUGH REMOVABLE GLAND PLATE RECOMMENDED
- USE WATERTIGHT CONDUIT CONNECTOR ONLY.
- PROTECT EQUIPMENT AGAINST DRILLING CHIPS.
- AMBIENT TEMPERATURE : BETWEEN 41°F (5°C) AND 104°F (40°C).

Drawing for information only.  
 Manufacturer reserves the right to modify this drawing without notice.  
 Contact manufacturer for "As Built" drawing.

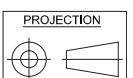

REV.	DATE	DESCRIPTION	APP.
8.	13/01/29	FEET	
7.	13/01/14	HP TABLE	DES.
6.	12/07/20	PLATE DIM. AND IDENTIFI.	VER.

DRAWING No. **GPX-DI121** /E



# ELECTRIC FIRE PUMP CONTROLLER REDUCED VOLTAGE / AUTOTRANSFORMER

MODEL :GPR

## Wiring schematic

BUILT TO THE LATEST EDITION OF THE NFPA20 STANDARD

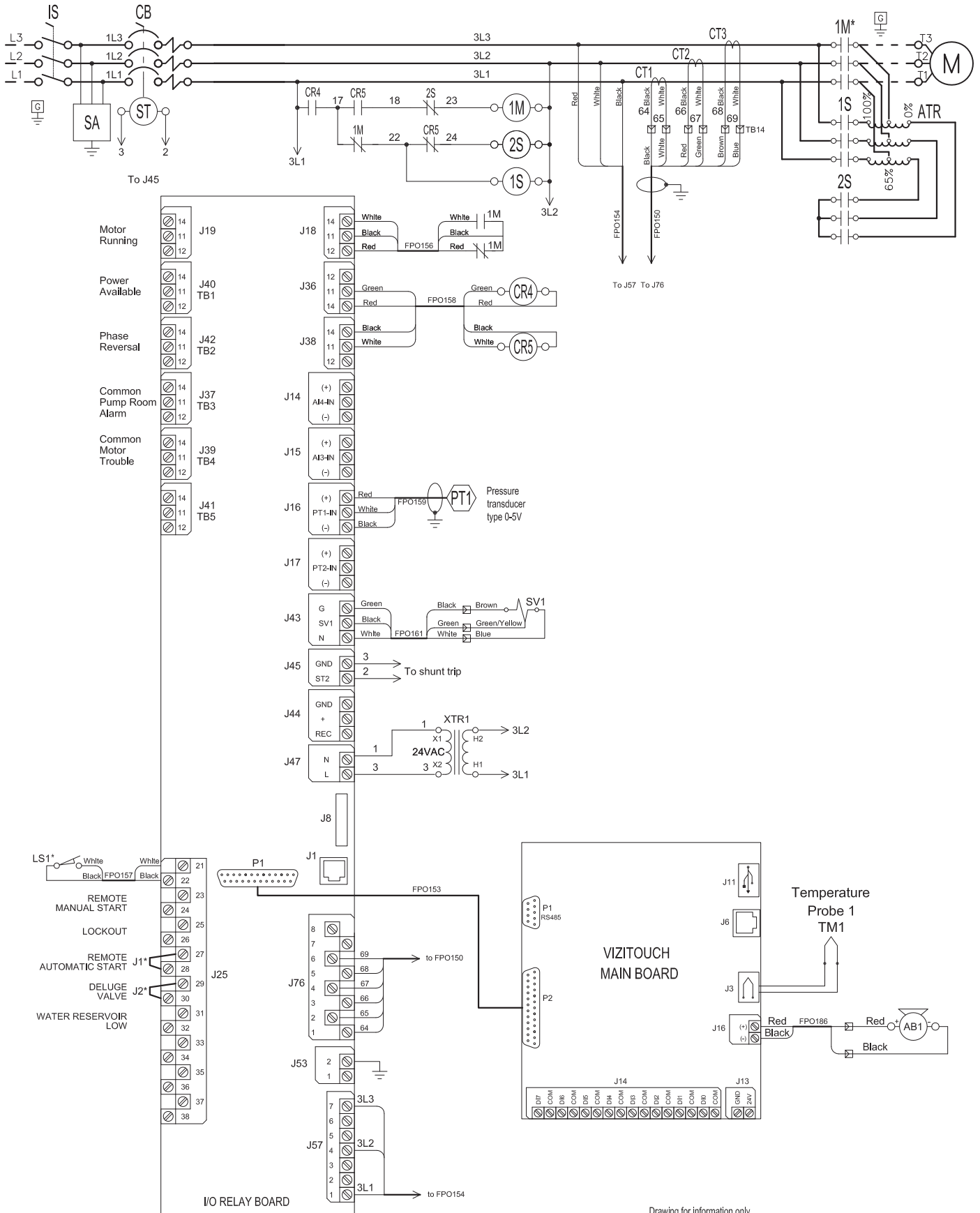

Drawing for information only.  
Manufacturer reserves the right to modify this drawing without notice.  
Contact manufacturer for "As Built" drawing.

\* REMOVE JUMPER TO USE THIS FEATURE

\* Contact closed when Emergency Start is in ON position

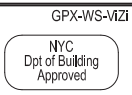

REV.	DATE	DESCRIPTION	APP.
2.	12/05/30	General Revision	DES.
1.	12/05/30	Correct Signal Input	VER.

Drawing No.  
GPR-WS500 /E



### Power Terminals

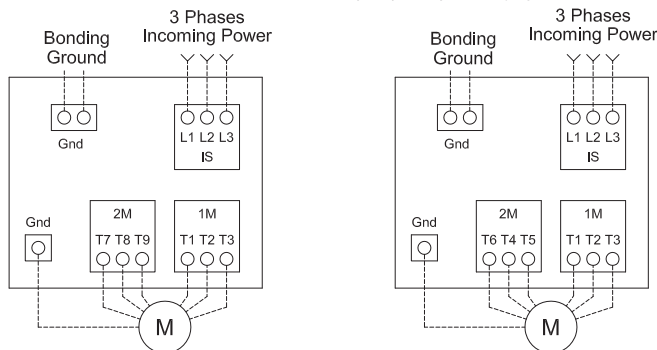

Model : GPP

Models : GPW & GPY

- Notes:
- 1 - For proper wire sizing, refer to NFPA70 and NEC (USA) or CEC (Canada) or local code.
  - 2 - Controller suitable for service entrance in USA.
  - 3 - For more accurate motor connections refer to motor manufacturer or motor nameplate.
  - 4 - Controller is phase sensitive. Incoming lines must be connected in ABC sequence.
  - 5 - Field wiring and lug sizes base on copper conductors only.  
Do not use aluminium conductors.

### Isolating Switch (IS) Field Wiring according to Bending Space (AWG or MCM). TERMINALS L1 - L2 - L3

(Use Copper Conductors Only)

Bending Space	5 " (127 mm)							8 " (203 mm)		
	HP	5	7.5	10	15	20	25	30	40	50
208	1x (10 to 1/0)	1x (8 to 1/0)	1x (8 to 1/0)	1x (6 to 1/0)	1x (4 to 1/0)	1x (3 to 1/0)	1x (2 to 1/0)	1x (1/0 to 250)	1x (3/0 to 250)	1x (4/0 to 250)
220 to 240	1x (10 to 1/0)	1x (10 to 1/0)	1x (8 to 1/0)	1x (6 to 1/0)	1x (4 to 1/0)	1x (4 to 1/0)	1x (3 to 1/0)	1x (1 to 250)	1x (2/0 to 250)	1x (3/0 to 250)
380 to 416	1x (10 to 1/0)	1x (10 to 1/0)	1x (10 to 1/0)	1x (8 to 1/0)	1x (8 to 1/0)	1x (6 to 1/0)	1x (6 to 1/0)	1x (4 to 1/0)	1x (3 to 1/0)	1x (3 to 1/0)
440 to 480	1x (10 to 1/0)	1x (10 to 1/0)	1x (10 to 1/0)	1x (10 to 1/0)	1x (8 to 1/0)	1x (8 to 1/0)	1x (6 to 1/0)	1x (6 to 1/0)	1x (4 to 1/0)	1x (3 to 1/0)
600	1x (10 to 1/0)	1x (10 to 1/0)	1x (10 to 1/0)	1x (10 to 1/0)	1x (10 to 1/0)	1x (8 to 1/0)	1x (8 to 1/0)	1x (6 to 1/0)	1x (6 to 1/0)	1x (4 to 1/0)

Bending Space	12 " (305 mm)				16 " (406 mm)							
	HP	75	100	125	150	200	250	300	350	400	450	500
208	1x (300 to 500)	1x (500)	2x (4/0 to 500)	2x (250 to 500)	2x (400 to 600)	-----	-----	-----	-----	-----	-----	-----
220 to 240	1x (250 to 500)	1x (350 to 500)	2x (3/0 to 500)	2x (4/0 to 500)	2x (350 to 500)	2x (500 to 600)	-----	-----	-----	-----	-----	-----
380 to 416	1x (1/0 to 250)	1x (3/0 to 250)	1x (250)	1x (300 to 500)	2x (3/0 to 250)	2x (4/0 to 500)	2x (300 to 500)	2x (400 to 500) 2x (400 to 500)	2x (500 to 600)	2x (600)	-----	-----
440 to 480	1x (1 to 250)	1x (2/0 to 250)	1x (3/0 to 250)	1x (4/0 to 250)	1x (350 to 500)	2x (3/0 to 250)	2x (4/0 to 500)	2x (300 to 500)	2x (350 to 500)	2x (400 to 600)	2x (500 to 600)	-----
600	1x (3 to 1/0)	1x (1 to 250)	1x (2/0 to 250)	1x (3/0 to 250)	1x (250 to 500)	1x (350 to 500)	2x (3/0 to 250)	2x (4/0 to 500)	2x (250 to 500)	2x (300 to 500)	2x (350 to 500)	-----

Bending Space	5 " (127 mm)	8 " (203 mm)	12 " (305 mm)
HP	75	100	125

### Wiring Size for motor connection for Model GPP, GPW and GPY (AWG or MCM). TERMINALS T1 - T2 - T3 - T4 - T5 - T6 - T7 - T8 - T9

(Use Copper Conductors Only)

HP	5	7.5	10	15	20	25	30	40	50	60
208	1x (14 to 10)	1x (12 to 10)	1x (10)	1x (8 to 2)	1x (8 to 2)	1x (6 to 2)	1x (6 to 1/0)	1x (4 to 2/0)	1x (2 to 3/0)	1x (1 to 3/0)
220 to 240	1x (14 to 10)	1x (12 to 10)	1x (10)	1x (8 to 2)	1x (8 to 2)	1x (6 to 2)	1x (6 to 1/0)	1x (4 to 2/0)	1x (3 to 2/0)	1x (2 to 3/0)
380 to 416	1x (14 to 10)	1x (14 to 10)	1x (14 to 10)	1x (12 to 10)	1x (10)	1x (10)	1x (8 to 2)	1x (6 to 2)	1x (6 to 2)	1x (4 to 1/0)
440 to 480	1x (14 to 10)	1x (14 to 10)	1x (14 to 10)	1x (12 to 10)	1x (12 to 10)	1x (10)	1x (10 to 2)	1x (8 to 2)	1x (6 to 2)	1x (6 to 2)
600	1x (14 to 10)	1x (14 to 10)	1x (14 to 10)	1x (14 to 10)	1x (12 to 10)	1x (12 to 10)	1x (10)	1x (10 to 2)	1x (8 to 2)	1x (8 to 2)

HP	75	100	125	150	200	250	300	350	400	450	500
208	1x (2/0 to 3/0)	1x (3/0)	1x (250 to 300)	2x (1/0 to 300)	2x (3/0 to 350)	-----	-----	-----	-----	-----	-----
220 to 240	1x (1/0 to 3/0)	1x (3/0)	1x (4/0 to 300)	1x (300)	2x (2/0 to 300)	2x (4/0 to 350)	-----	-----	-----	-----	-----
380 to 416	1x (4 to 2/0)	1x (2 to 2/0)	1x (1/0 to 3/0)	1x (2/0 to 3/0)	1x (4/0 to 300)	1x (300)	2x (2/0 to 300)	2x (3/0 to 300)	2x (4/0 to 350)	2x (4/0 to 350)	-----
440 to 480	1x (4 to 2/0)	1x (3 to 2/0)	1x (2 to 3/0)	1x (1/0 to 3/0)	1x (2/0 to 3/0)	1x (4/0 to 300)	1x (300)	2x (1/0 to 300)	2x (2/0 to 300)	2x (3/0 to 350)	2x (4/0 to 350)
600	1x (6 to 2)	1x (4 to 2/0)	1x (3 to 2/0)	1x (2 to 3/0)	1x (1/0 to 3/0)	1x (2/0 to 3/0)	1x (4/0 to 300)	1x (250 to 300)	1x (300)	2x (1/0 to 300)	2x (2/0 to 300)

Drawing for information only.  
 Manufacturer reserves the right to modify this drawing without notice.  
 For drawing for approval or installation, please contact manufacturer.



REV.	DATE	DESCRIPTION	APP.
4.	13/11/11	FIELD PROGRAMMABLE	DES.
3.	13/01/04	DATA ADDED TO TABLES	VER.

Drawing No.  
**GPX-TD500 2/3 /E**

### Remote Alarm Terminals (I/O board)

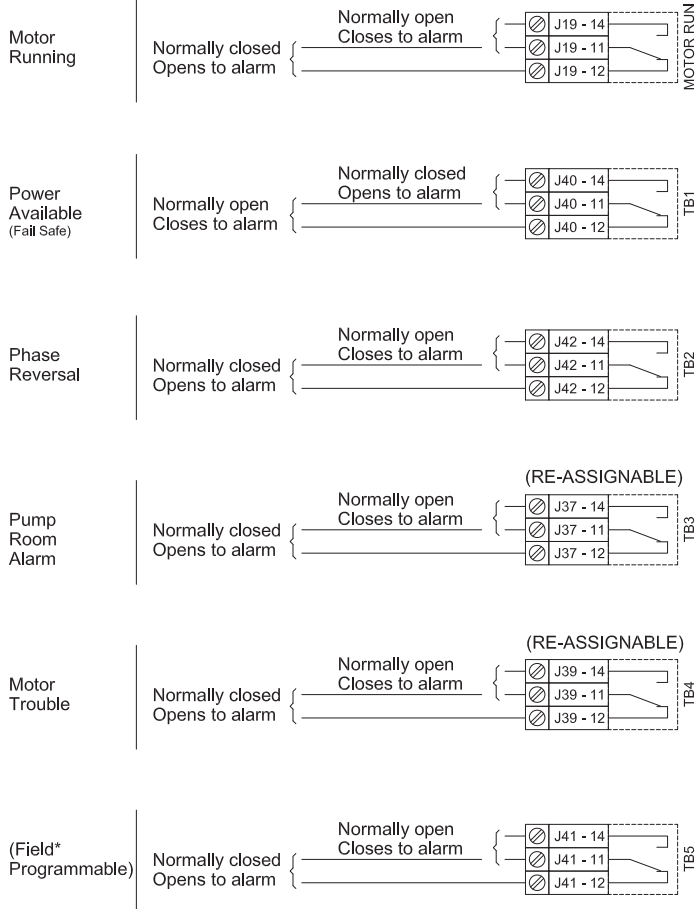

### Control Terminals (I/O board)

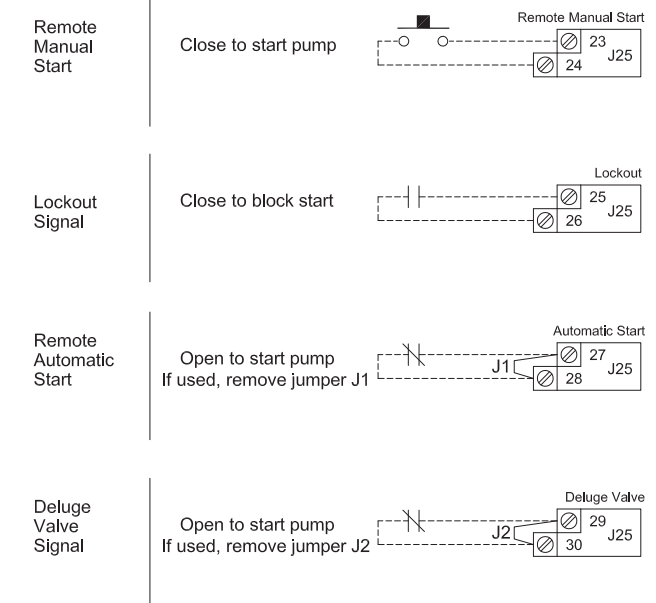

### Filed Connections for External Devices (I/O board)

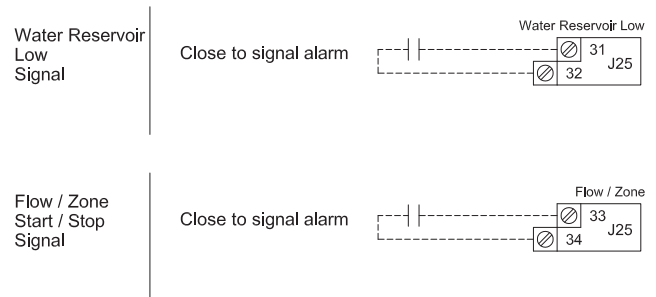

Drawing for information only.  
 Manufacturer reserves the right to modify this drawing without notice.  
 For drawing for approval or installation, please contact manufacturer.

\*Not Available in GPS Models



REV.	DATE	DESCRIPTION	APP.
4.	13/11/11	FIELD PROGRAMMABLE	DES.
3.	13/01/04	DATA ADDED TO TABLES	VER.
2.			
1.			

Drawing No. GPX-TD500 3/3 /E